

TJ-56-428 4Bit Digital Electronic Clock DIY Kit

I. Introduction:

TJ-56-428 is a 4Bit Digital Electronic Clock DIY Kit. It will display current date, time, temperature in the real time, Alarm clock music. User can set alarm as your needs. It is easy to operate, beautiful design, very suitable for home or office environment.

II. Feature:

- 1>.Yellow-green mixed color display
- 2>.Automatic brightness adjustment
- 3>.Time/Date/Alarm/Temperature
- 4>.Adjustable alarm clock music
- 5>.Time memory function
- 6>.Temperature value can be calibrated
- 7>.Voice Hourly Report
- 8>.DIY manual soldering
- 9>.Simple and easy to operate

III. Parameter:

- 1>.Item name: TJ-56-428 4Bit Digital Electronic Clock DIY Kit
- 2>.Model:TJ-56-428
- 3>.Work voltage:DC 5V
- 4>.Display color:Yellow-green mixed color
- 5>.Work Temperature:-20°C~85°C
- 6>.Work Humidity:0%~95%RH
- 7>.Size(Installed):77*33*25mm

IV. Main Function:

- 1>.Display time: Hour, Minute, Second.
- 2>.Display date: Year, Month, Day.
- 3>.Display week.
- 4>.Display current temperature in Celsius.
- 5>.Adjustable alarm clock music: 4 music.
- 6>.Voice Hourly Report.
- 7>.Automatic brightness adjustment.
- 8>.Adjustable volume.
- 9>.Set display mode.
- 10>.Calibration temperature display value.

V. Set Method:

1>.It displays the current time by default in hour-minute. Note:

2>.Press S1/left button to display month-day, week, year.

3>.Press S2/right button to display temperature, alarm time, minute-second.

4>.Set Method:

4.1>.Keep press two buttons about 3 second enter into set mode.

4.2>.Short press S1/left button to switch set mode from Fu-1 to Fu-5. The parameter 1~5 will flash automatically.

4.3>.Short press S2/right button to selected mode.

4.4>.The selected or setting parameters will flash automatically.

4.5>.S1/left button is used to change value.Note: The value just can increase and then start to increase again.

4.6>.S2/right button is used to set parameter or confirm selected.

5>.Fu-1 mode:Set time in Hour:Minute.

5.1>.Set Hour: Short press S1/left button to set value for current hour.

5.2>.Set Minute: Short press S2/right button to select set for minute.And then press S1/left button to set value for current minute.

5.3>.Press S2/right button again to save and exit set mode.

6>.Fu-2 mode:Set date in Month, Day and Year.

6.1>.Set Month: Short press S1/left button to set value for current month.

6.2>.Set Day: Short press S2/right button to select set for day.And then press S1/left button to set value for current day.

6.3>.Set Day: Short press S2/right button to select set for year.And then press S1/left button to set value for current year. It can display from 2000 to 2099.

6.4>.Press S2/right button again to save and exit set mode.

7>.Fu-3 mode:Set alarm time in Hour:Minute.

7.1>.Set Hour: Short press S1/left button to set value for alarm hour. Note: the hour can be set 24 which means turn OFF alarm.

7.2>.Set Minute: Short press S2/right button to select set for minute.And then press S1/left button to set value for alarm minute.

7.3>.Press S2/right button again to save and exit set mode.

8>.Fu-4 mode: Set Hourly Report, Display Mode, Set Brightness.

8.1>.It can display 4bit: The first bit is used to set Hourly Report. The second bit is used to set Display Mode and the last two bit are used to set Brightness.

8.2>.Set Hourly Report:

8.2.1>.Short press S1/left button to disable and enable Hourly Report function.

8.2.2>. '1' means enable Hourly Report function.

8.2.3>. '0' means disable Hourly Report function.

8.3>.Set Display Mode:

8.3.1>.Short press S2/right button to select set the second bit to set display mode. And then press S1/left button to switch display mode.

8.3.2>. '0' means just display time.

8.3.2>. '1' means display time and interval display temperature. The interval time

is about 59 second and display temperature in 1 second. That is, the temperature is displayed for 1 second every minute.

8.3.3>. '2' means display time and interval display date and temperature. The interval time is about 58 second and display date in 1 second and display temperature in 1 second. That is, the temperature and date are displayed for 1 second each minute.

8.3.4>. '3' means just display temperature. Note: In this mode, user can calibration temperature value at normal display interface by two buttons.

8.4>.Set Brightness.

8.4.1>.Short press S2/right button to select set the last two bits to set display brightness. And then press S1/left button to switch display mode.

8.4.2>. 'A' means the display brightness is automatically adjusted according to the ambient brightness.

8.4.3>. '1' to '15' means set the brightness level. The brightness of the display will not change.

8.5>.Press S2/right button again to save and exit set mode.

8.6>.E.g. '1215' means: Enable Hourly Report function; Display time and interval display date and temperature; The brightness level is 15.

9>.Fu-5 mode: set Alarm Clock Music, set Volume.

9.1>.Set Alarm Clock Music: Short press S1/left button to select 4 music.

9.2>.Set Day: Short press S2/right button to select set volume.And then press S1/left button to set volume value from '4' to '40'. Maximum volume when '40' is displayed.

9.3>.Press S2/right button again to save and exit set mode.

VI. Note:

1>.Garbled characters are displayed when the power is turned on for the first time, and the settings need to be completed before they can be displayed correctly.

2>.When calibrating the temperature value, user must select only temperature display mode at first.

VII. Component listing:

NO.	Component Name	PCB Marker	Parameter	QTY
1	Metal Film Resistor	R13,R16,R18,R19,R21	10Kohm	5
2	Metal Film Resistor	R14	20Kohm	1
3	Metal Film Resistor	R20	510ohm	1
4	Ceramic Capacitor	C1,C2	0.1uF 104	2
5	Ceramic Capacitor	C4,C5	5pF	2
6	Electrolytic Capacitor	C3	100uF	1
7	GL5516 Photoresistor	R15		1
8	Thermistor	R17	10Kohm NTC	1
9	S8550 Transistor	Q1	TO-92	1
10	Passive Buzzer	LS1		1

11	0.56in 4Bit Digital Tube	DS1	Yellow-Green	1
12	1N4148 Diode	D1	DO-35	1
13	DC Power Socket	DC	3.5*1.2mm	1
14	CR1220 Battery	BT1	3V	1
15	CR1220 Battery Socket	BT1	SMD	1
16	Black Button	S1,S2	6*6*5mm	1
17	STC15W404AS	U1	DIP-20	1
18	IC Socket	U1	DIP-20	1
19	DS1302 Clock IC	U2	DIP-8	1
20	IC Socket	U2	DIP-8	1
21	Crystal Oscillator	Y2	32.768KHz	1
22	USB Power Wire			1
23	Acrylic Board			6
24	M2*25mm Screw			4
25	M2 Nut			4
26	PCB		70*25*1.6mm	1
Note:Users can complete the installation according to the PCB silk screen and component list.				

VIII. Application:

- 1>.Practical at home
- 2>.Indoor display
- 3>.Simple appearance, easy office
- 4>.Wall decoration

IX. Installation Tips:

- 1>.User needs to prepare the soldering tool at first.
- 2>.Please be patient until the installation is complete.
- 3>.The package is DIY kit.It need finish install by user.
- 4>.The soldering iron can't touch the components for a long time(1.0 second), otherwise it will damage the components.
- 5>.Pay attention to the positive and negative of the components.
- 6>.Strictly prohibit short circuit.
- 7>.Install complex components preferentially.
- 8>.Make sure all components are in right direction and right place.
- 9>.Please wear anti-static gloves or anti-static wristbands when installing electronic components.
- 10>.It is strongly recommended to read the installation manual before starting installation!!!

X. Installation Steps(Please be patient install!!!):

- 1>.Step 1: Install 5pcs 10Kohm Metal Film Resistor at R13,R16,R18,R19,R21.
- 2>.Step 2: Install 1pcs 20Kohm Metal Film Resistor at R14.

- 3>.Step 3: Install 1pcs 510ohmMetal Film Resistor at R20.
- 4>.Step 4: Install 1pcs Thermistor at R17.
- 5>.Step 5: Install 1pcs DO-35 1N4148 Diode at D1. Pay attention to the installation direction. Note: The black mark on Diode and the white mark on PCB are corresponding.
- 6>.Step 6: Install 1pcs GL5516 GL5516 Photoresistor at R15 on PCB another side.
- 7>.Step 7: Install 1pcs DIP-20 IC Socket at U1. There is a mark(notch) on one end of the IC Socket and there is a mark(curved silk screen printing) on PCB where the IC Socket can place on. These two marks are corresponding to each other and are used to specify the installation direction of the IC Socket.
- 8>.Step 8: Install 1pcs DIP-8 IC Socket at U2. There is a mark(notch) on one end of the IC Socket and there is a mark(curved silk screen printing) on PCB where the IC Socket can place on. These two marks are corresponding to each other and are used to specify the installation direction of the IC Socket.
- 9>.Step 9: Install 2pcs 5pF Ceramic Capacitor at C4,C5.
- 10>.Step 10: Install 2pcs 0.1uF 104 Ceramic Capacitor at C1,C2.
- 11>.Step 11: Install 1pcs CR1220 Battery Socket at BT1.
- 12>.Step 12: Install 1pcs TO-92 S8550 Transistor at Q1. Pay attention to the installation direction of arc.
- 13>.Step 13: Install 1pcs 3.5*1.2mm DC Power Socket at DC.
- 14>.Step 14: Install 1pcs 32.768K Crystal Oscillator at Y2.
- 15>.Step 15: Install 1pcs 100uF Electrolytic Capacitor at C3. Pay attention to distinguish between positive and negative. The shorter pin is negative pole and insert into white pad.
- 16>.Step 16: Install 1pcs Passive buzzer at LS1. Pay attention to the installation direction.
- 17>.Step 17: Install 2pcs 6*6*5mm Black Button at S1,S2.
- 18>.Step 18: Install 1pcs 0.56in 4Bit Digital Tube at DS1 on PCB another side. Pay attention to the installation direction of the decimal point.
- 19>.Step 19: Install 1pcs DIP-20 IC STC15W404AS at U1. There is a mark(notch) on one end of the IC Socket and there is a mark(curved silk screen printing) on PCB where the IC can place on. These two marks are corresponding to each other and are used to specify the installation direction of the IC.
- 20>.Step 20: Install 1pcs DIP-8 IC DS1302 Clock Chip at U2 in the same method.
- 21>.Step 21: Install 1pcs 3V CR1220 Battery on battery socket. Pay attention to the direction of the battery.
- 22>.Step 22: Tear off the protective film on the black acrylic surface.
- 23>.Step 23: Fixed bottom acrylic plate by 4pcs M2*25mm Screw.
- 24>.Step 24: Place 4pcs acrylic plate on side and PCB on bottom acrylic plate.
- 25>.Step 25: Fixed all acrylic plate 4pcs M2 Nut.
- 26>.Step 26: Connect to power supply and set parameters according to set method.

XI. Install shown steps:

Step 1: Install 5pcs 10Kohm Metal Film Resistor at R13,R16,R18,R19,R21.

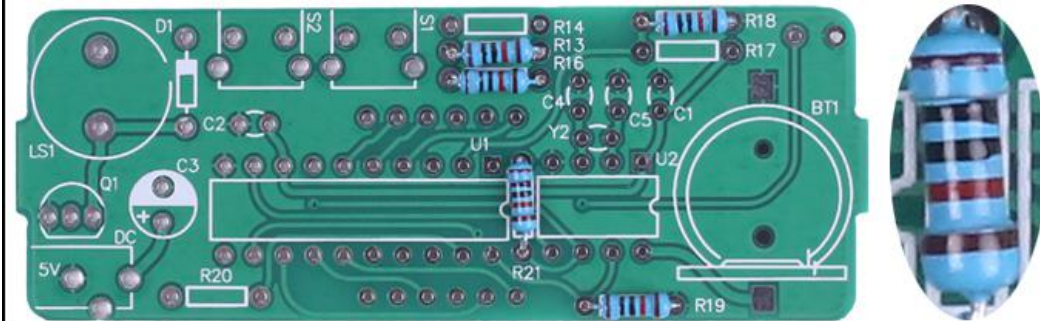

Step 2: Install 1pcs 20Kohm Metal Film Resistor at R14.

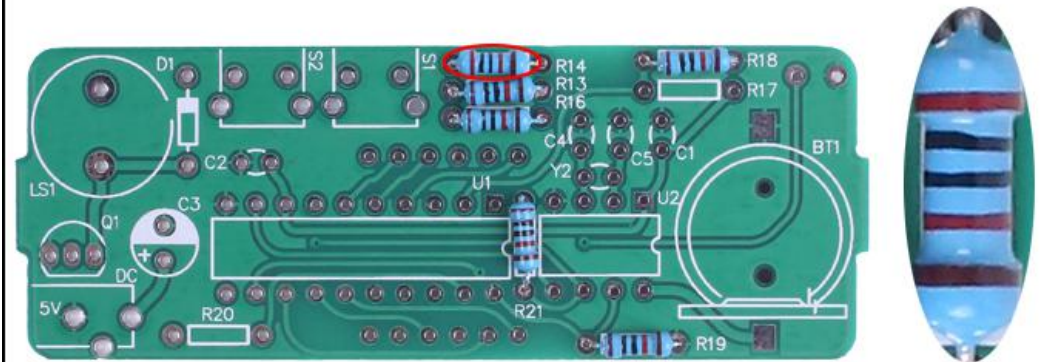

Step 3: Install 1pcs 510ohm Metal Film Resistor at R20.

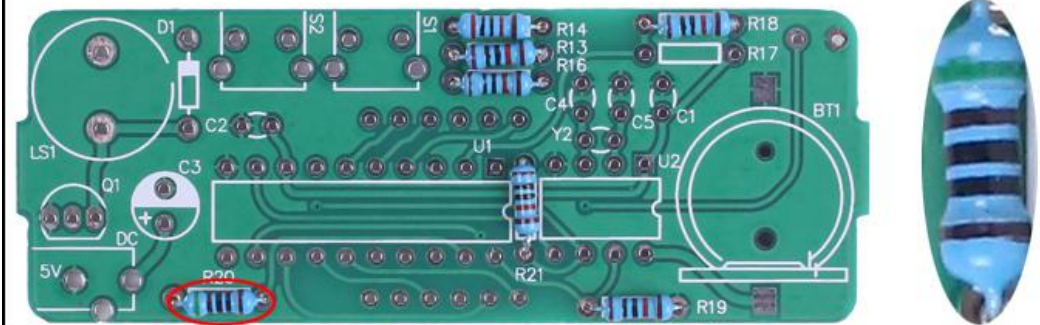

Step 4: Install 1pcs Thermistor at R17.

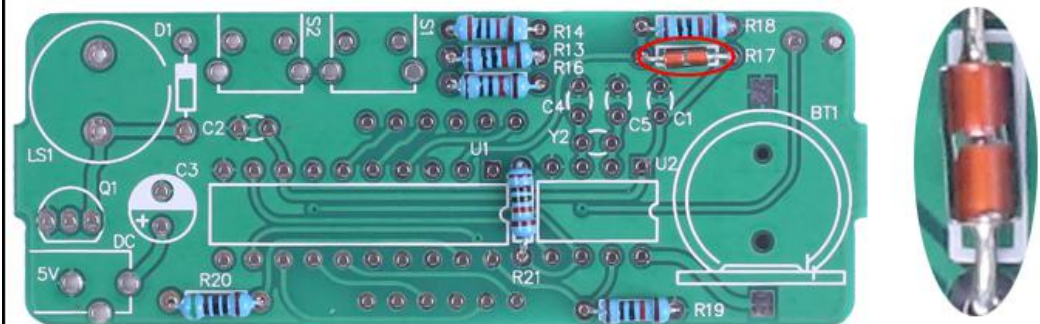

Step 5: Install 1pcs DO-35 1N4148 Diode at D1. Pay attention to the installation direction. Note: The black mark on Diode and the white mark on PCB are corresponding.

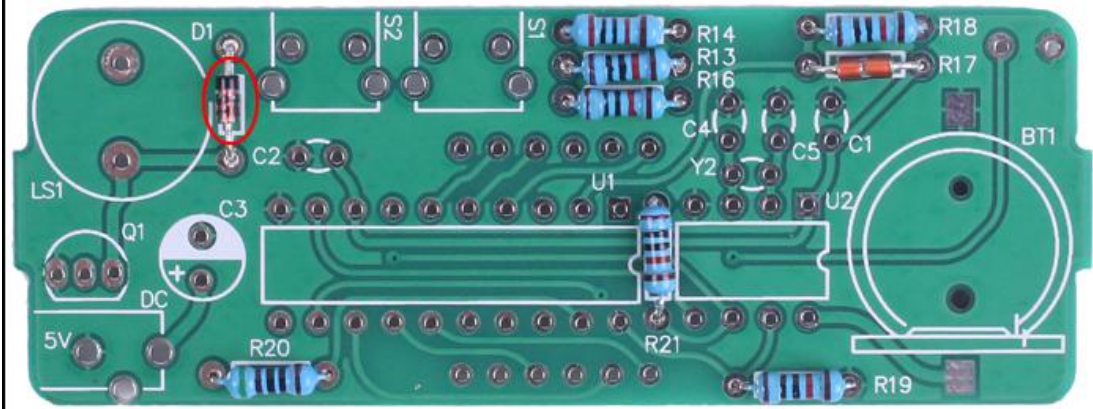

Step 6: Install 1pcs GL5516 GL5516 Photoresistor at R15 on PCB another side.

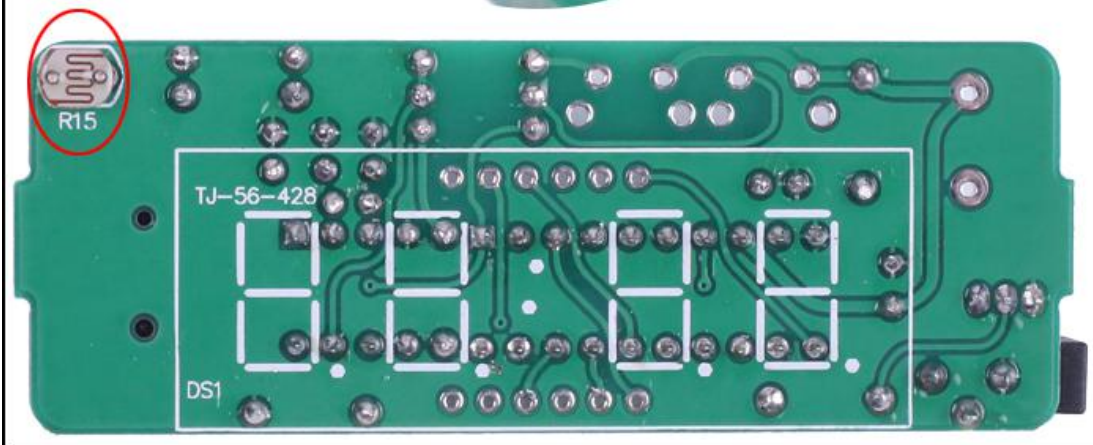

Step 7: Install 1pcs DIP-20 IC Socket at U1. There is a mark(notch) on one end of the IC Socket and there is a mark(curved silk screen printing) on PCB where the IC Socket can place on. These two marks are corresponding to each other and are used to specify the installation direction of the IC Socket.

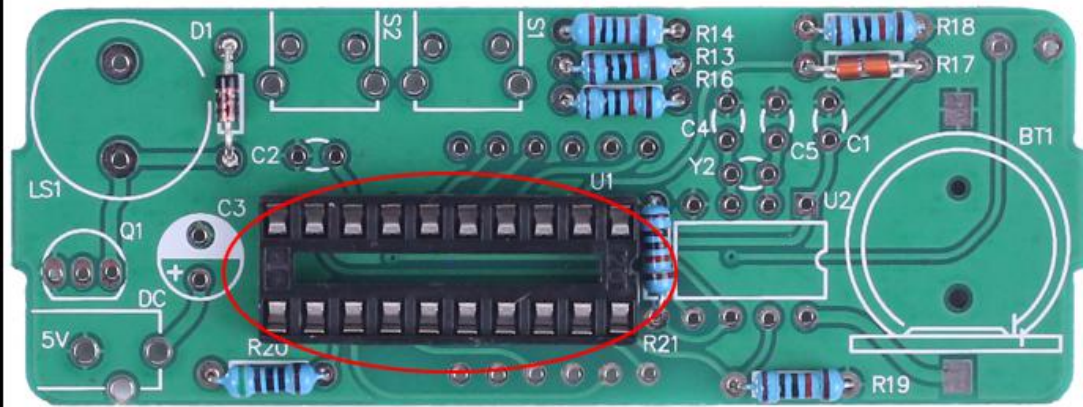
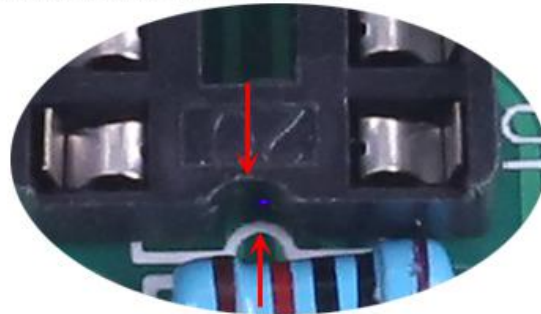

Step 8: Install 1pcs DIP-8 IC Socket at U2. There is a mark(notch) on one end of the IC Socket and there is a mark(curved silk screen printing) on PCB where the IC Socket can place on. These two marks are corresponding to each other and are used to specify the installation direction of the IC Socket.

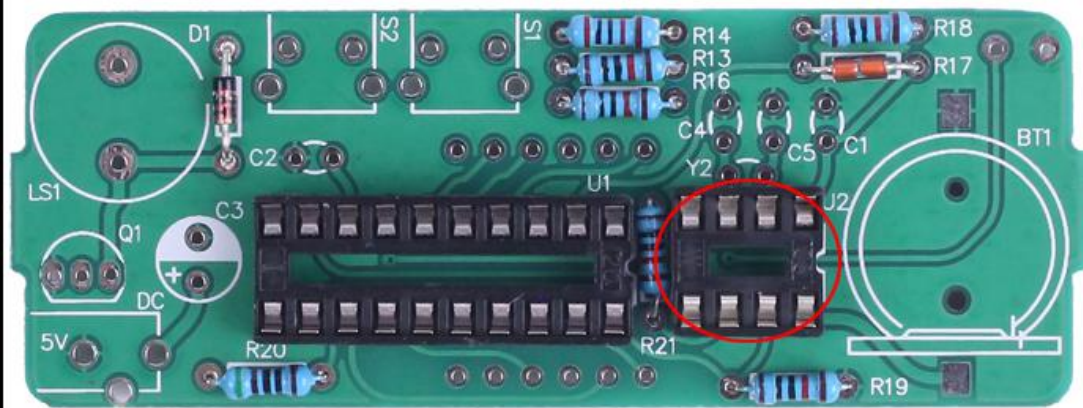
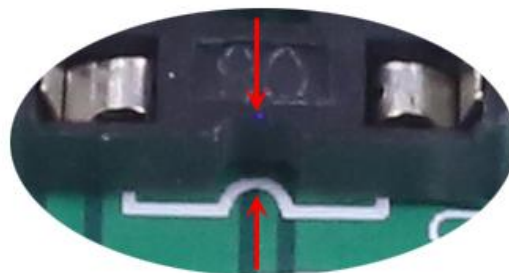

Step 9: Install 2pcs 5pF Ceramic Capacitor at C4,C5.

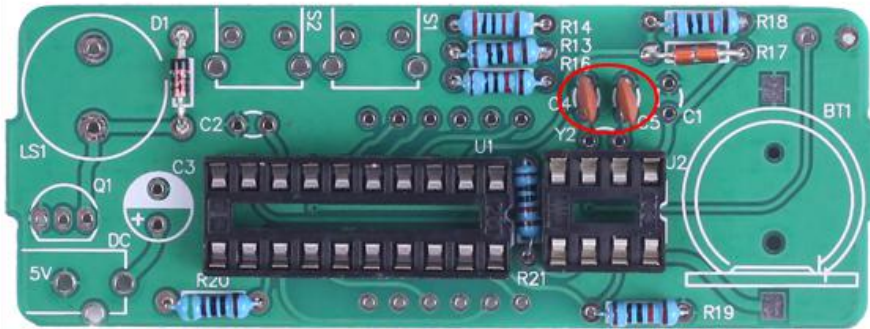

Step 10: Install 2pcs 0.1uF 104 Ceramic Capacitor at C1,C2.



Step 11: Install 1pcs CR1220 Battery Socket at BT1.

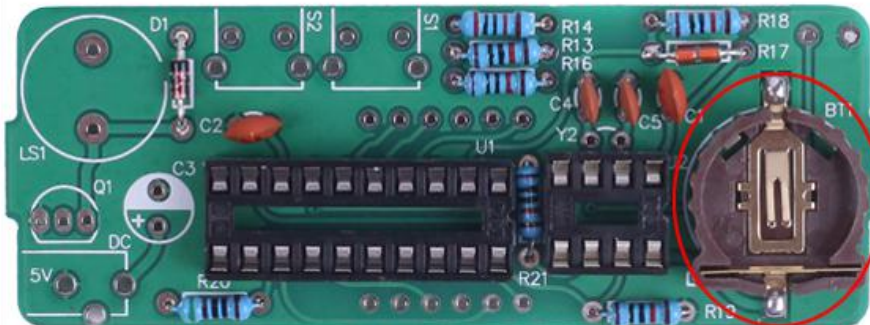

Step 12: Install 1pcs TO-92 S8550 Transistor at Q1. Pay attention to the installation direction of arc.

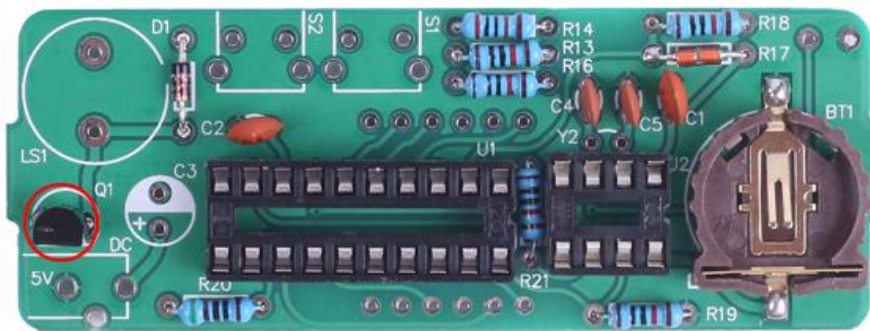

Step 13: Install 1pcs 3.5*1.2mm DC Power Socket at DC.

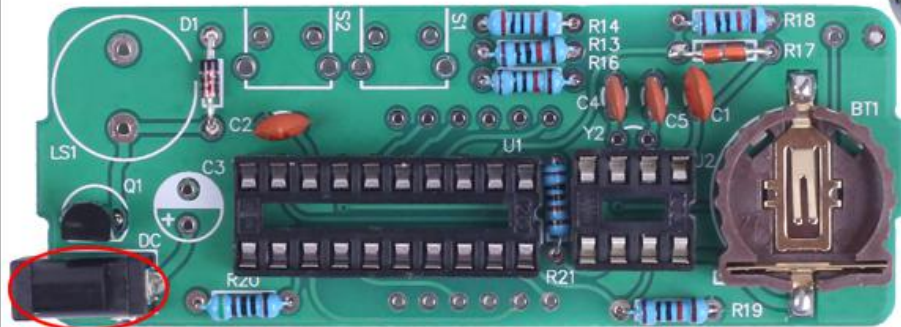

Step 14: Install 1pcs 32.768K Crystal Oscillator at Y2.

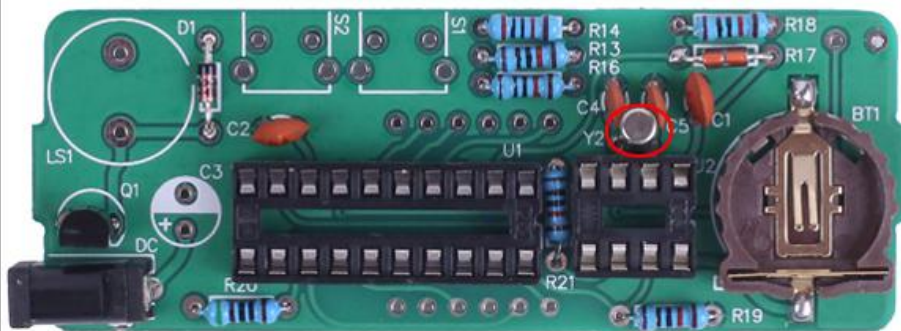

Step 15: Install 1pcs 100uF Electrolytic Capacitor at C3. Pay attention to distinguish between positive and negative. The shorter pin is negative pole and insert into white pad.

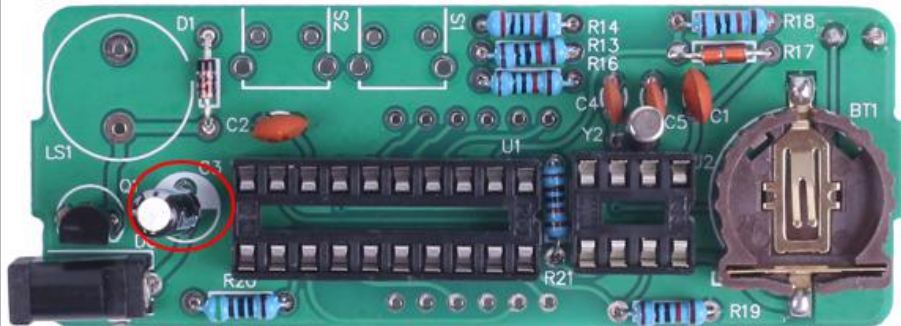

Shorter Pin



Step 16: Install 1pcs Passive buzzer at LS1. Pay attention to the installation direction.



Positive pole

Step 17: Install 2pcs 6*6*5mm Black Button at S1,S2.

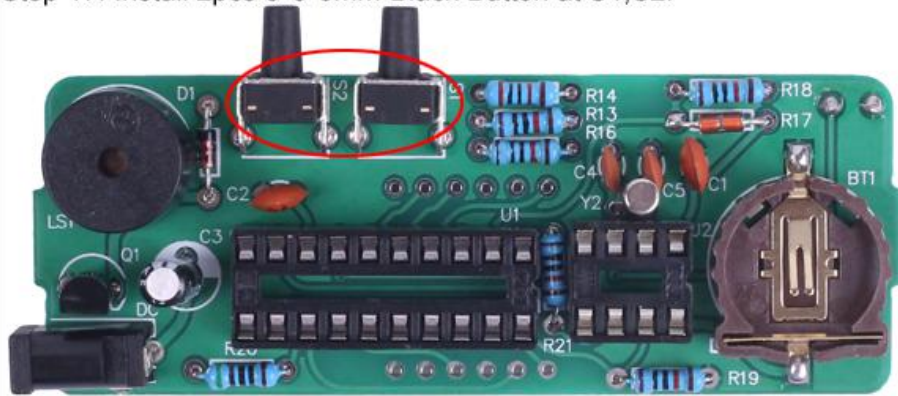

Step 18: Install 1pcs 0.56in 4Bit Digital Tube at DS1 on PCB another side. Pay attention to the installation direction of the decimal point.



Step 19: Install 1pcs DIP-20 IC STC15W404AS at U1. There is a mark(notch) on one end of the IC Socket and there is a mark(curved silk screen printing) on PCB where the IC can place on. These two marks are corresponding to each other and are used to specify the installation direction of the IC.

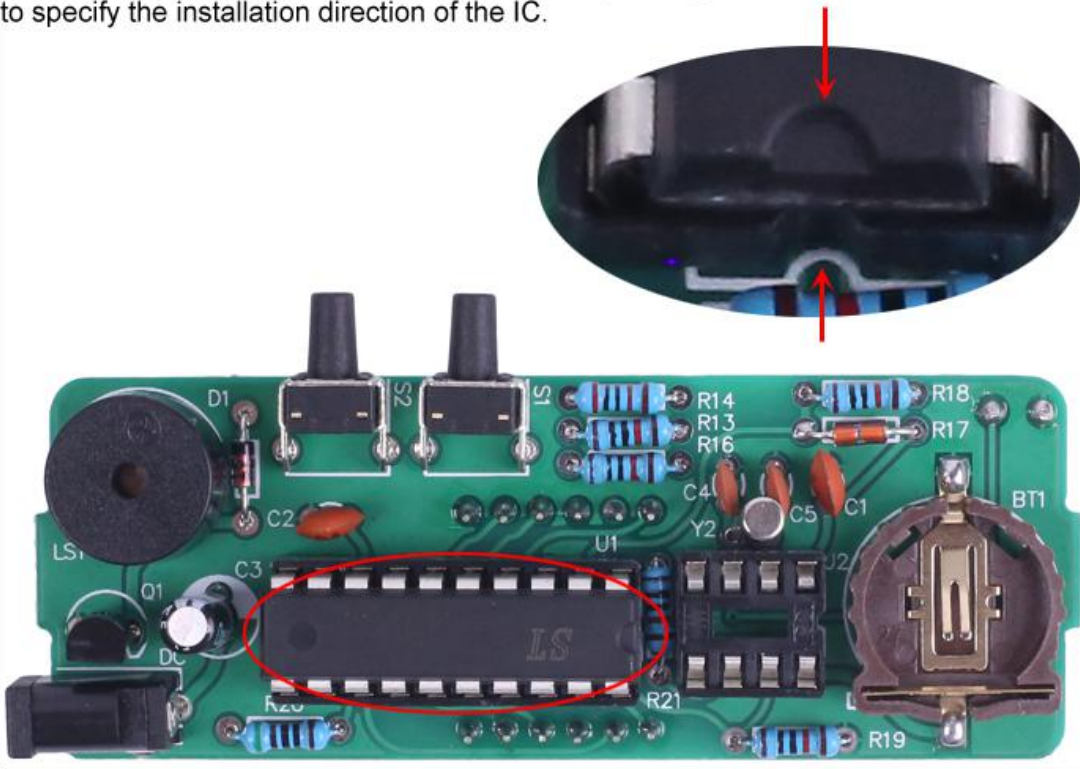

Step 20: Install 1pcs DIP-8 IC DS1302 Clock Chip at U2 in the same method.

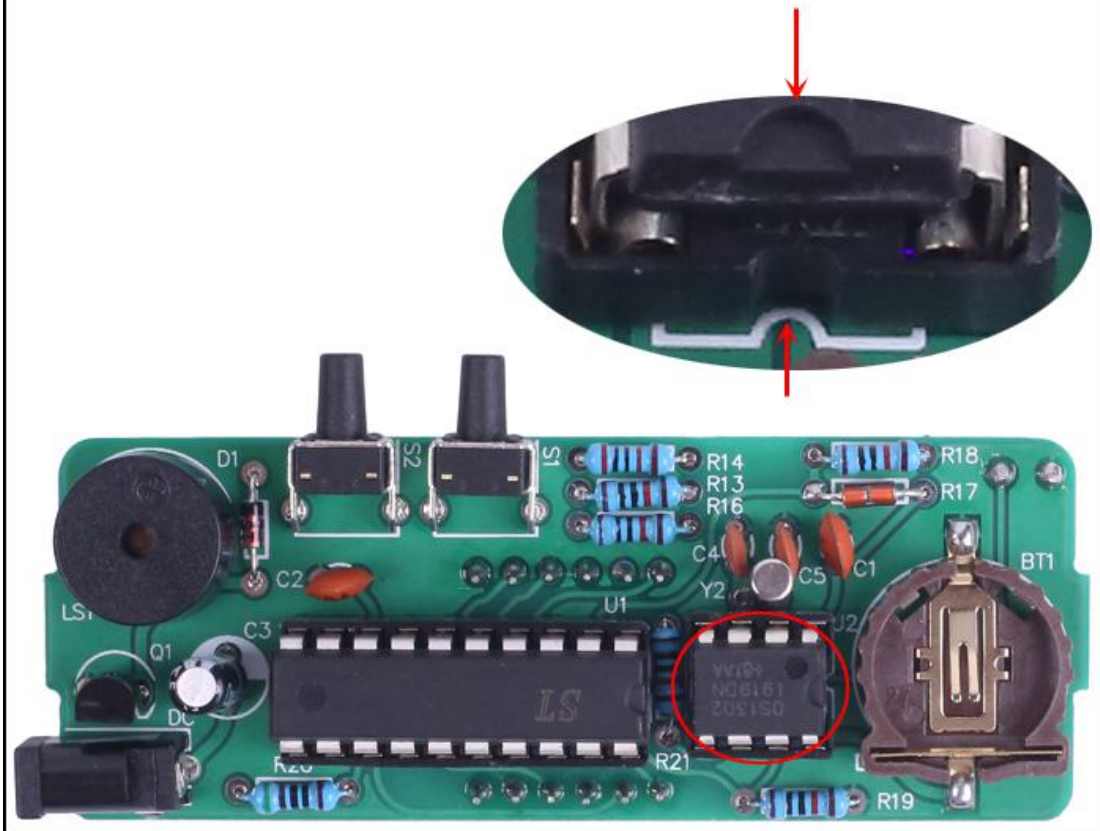

Step 21: Install 1pcs 3V CR1220 Battery on battery socket. Pay attention to the direction of the battery.

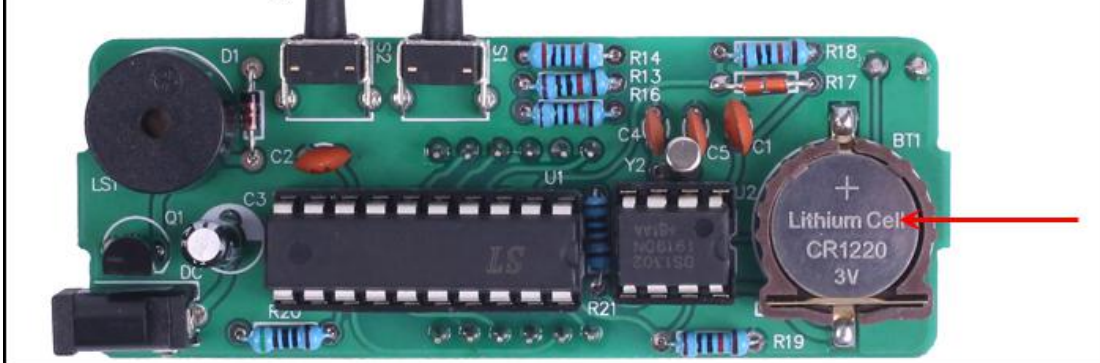

Step 22: Tear off the protective film on the black acrylic surface.

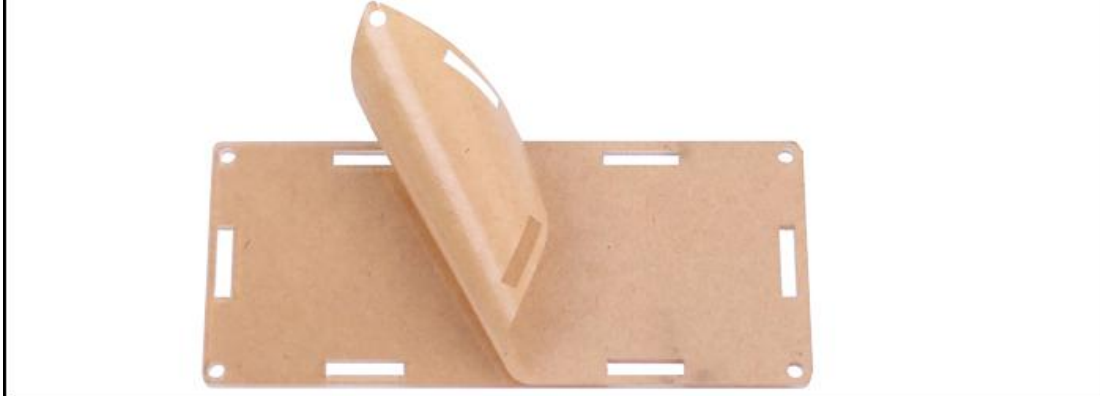

Step 23: Fixed bottom acrylic plate by 4pcs M2*25mm Screw.



Step 24: Place 4pcs acrylic plate on side and PCB on bottom acrylic plate.

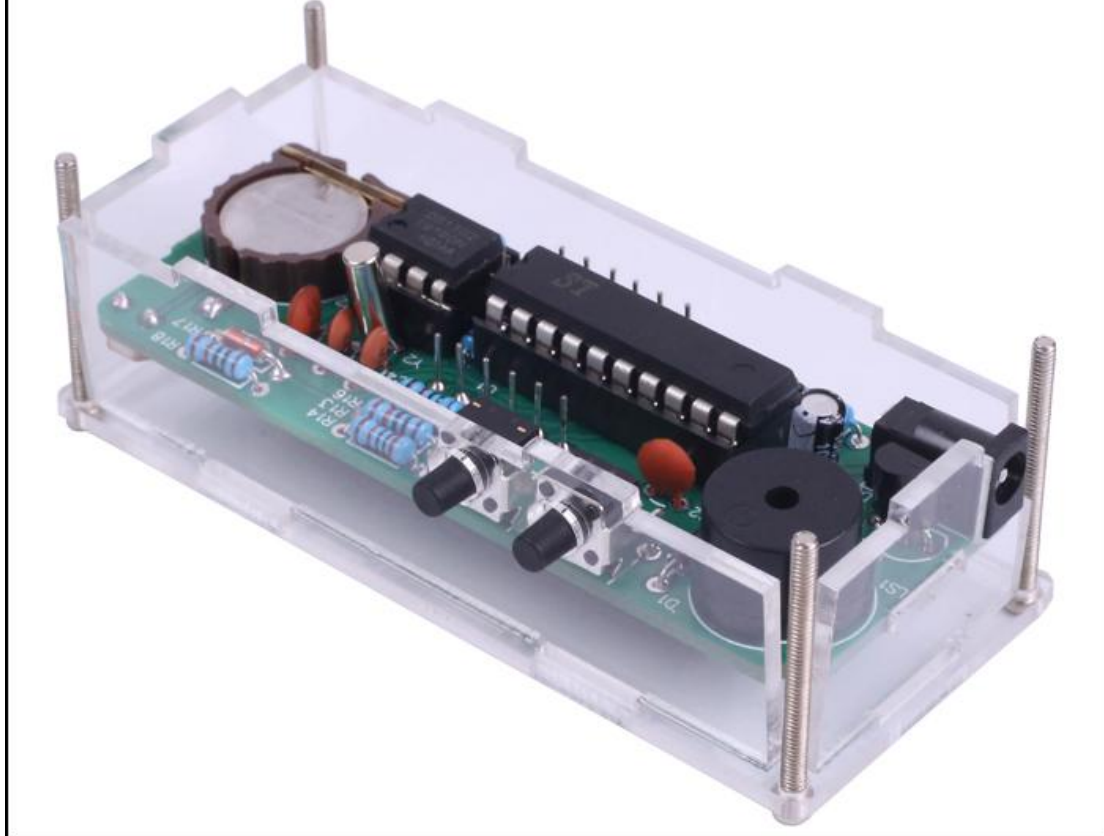

Step 25: Fixed all acrylic plate 4pcs M2 Nut.



Step 26: Connect to power supply and set parameters according to set method.

